

INSTRUCTIONS TO TEST AND REPLACE (if necessary) FIXING BOLT

I. Tools Needed:

1. Torque Wrench
2. 10mm socket
3. Permanent colored marker (to identify inspected/repaired bolts)

II. Test Summary:

! WARNING

Avoid personal injury. This test should only be performed by trained and experienced bicycle mechanics. Consumers should not perform this test themselves.

Perform the test described below on the forks identified in the attached chart, “Fork Models Involved In The Investigation”. If the fixing bolt passes this test, the forks may be used. If the fixing bolt does not pass this test, the fixing bolt must be replaced.

Please note that some forks only have a fixing bolt on the right (drive) side of the fork leg, other models have a fixing bolt in both fork legs. See the attached chart for a complete list.

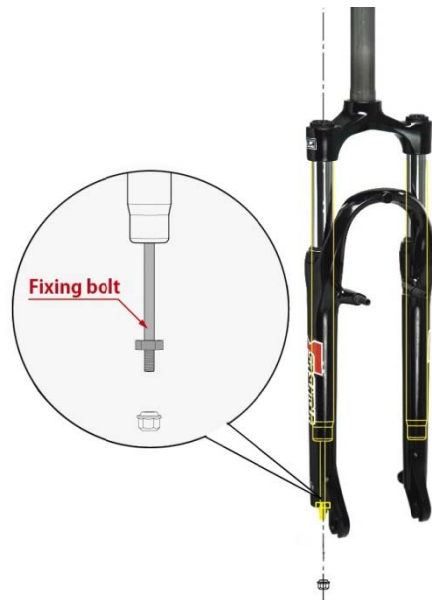

Figure: Single fixing bolt version
(Right Side Only)

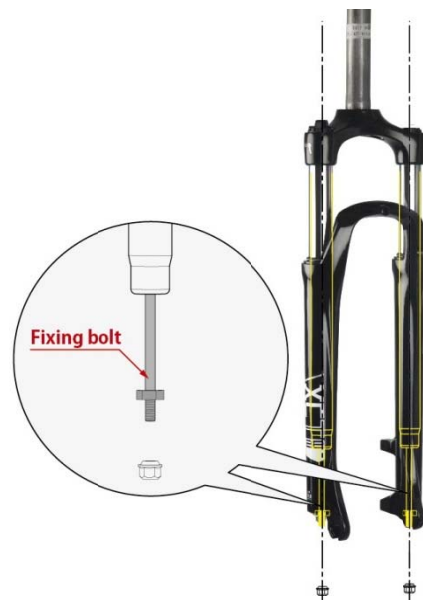

Figure: Two fixing bolts version
(Right and Left Sides)

Should you have any questions, contact SR SUNTOUR at fixingbolt@srsuntour-cycling.com or

1-888-820-8458.

III. FIXING BOLT INTEGRITY TEST PROCEDURE

A. For Fixing Bolt only in right (drive) side of fork leg

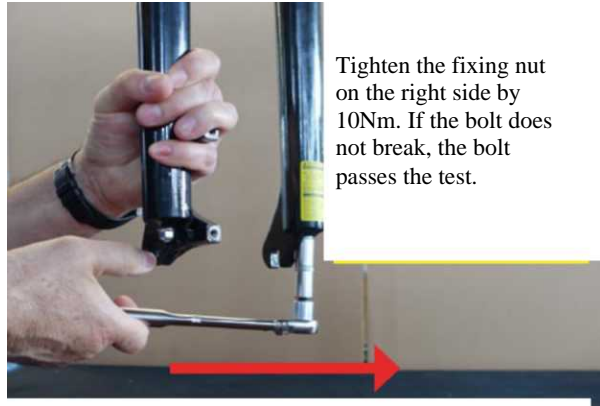
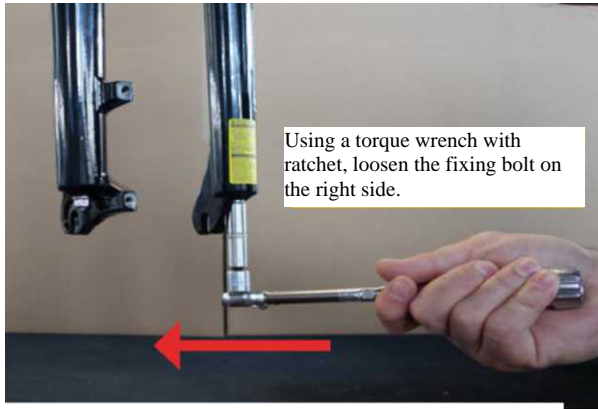

B. For fixing bolts in both fork legs

Conduct the test described above on both fork legs.

If all fixing bolts in a fork pass this Integrity Test, mark the fixing nuts with a permanent colored marker, in order to identify those fixing bolts that have been inspected and passed. The fork may be distributed in the normal course of your business.

If any fixing bolt in a fork does not pass this test, the fork may not be shipped until the failed fixing bolt is replaced. Go to step IV.

IV. FIXING BOLT REPLACEMENT PROCEDURE

A. Tools Needed:

- (1) 5mm Allen/hexagonal wrench 250mm long (for use with fixing bolt)
- (2) 13mm box wrench (use for the threaded washer)
- (4) 10mm socket
- (5) Torque wrench (use for fixing nut)
- (6) Plastic pre-load adjuster wrench
- (7) Permanent colored marker (to identify inspected/repaired bolts)

B. Additional Materials:

- (9) Work gloves
- (10) Cleaning rag and
- (11) Polybags (to be used for handling the greased spring)

C. Procedure:

1. Before beginning disassembly, place a piece of marking tape on the front side of the crown and on the bottom case to mark the front of the forks.
2. If the forks are equipped with two fixing bolts, and one of the fixing bolts passed the Fixing Bolt Integrity Test (Step III), use a 10 mm socket wrench to remove the nut on the end of the fixing bolt that passed the test.



3. Keep the nut from the “passed” fixing bolt for use later during reassembly of the forks.
4. Remove the bottom case.



5. Photograph below shows the bottom case removed.

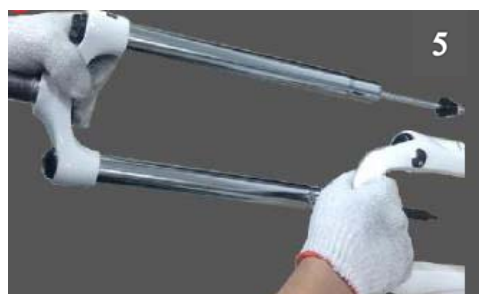

6. Use the plastic pre-load adjuster wrench to remove the pre-load adjuster knob above the “failed” fixing bolt. Do not remove the pre-load adjuster above the “passed” fixing bolt. If both fixing bolts failed the test, replace one fixing bolt at a time.



7. Pre-load adjuster knob removed. Please note the white spring guide is positioned so that it is facing above, towards the pre-load adjuster.



8. Remove the coil spring. In order to avoid grease contamination on your gloves, use a polybag.



9. Use a 5 mm x 250 mm long Allen/hexagonal wrench on the head of the “failed” fixing bolt to keep the fixing bolt from turning.



10. Place the 13 mm box wrench on the threaded washer. Use the 5 mm Allen/ hexagonal wrench and the 13 mm spanner to remove the threaded washer from the “failed” fixing bolt.



11. Remove the bottom stopper.

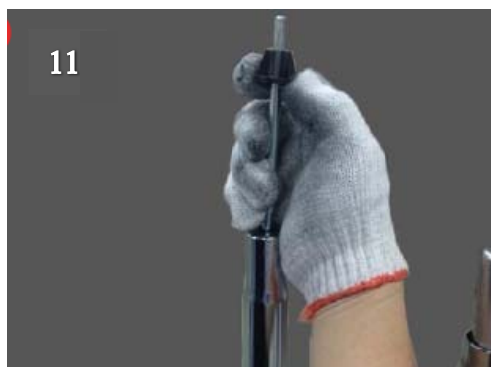

12. Remove the “failed” fixing bolt, rebound rubber, two (2) spring guides and coil spring from the stanchion.



13. Deposit the parts and “failed” fixing bolt in a red marked area and the new exchange bolt in a green area.



14. Install the rebound rubber, spring and the two (2) spring guides to the new bolt. Put the “failed” fixing bolt in the red area.

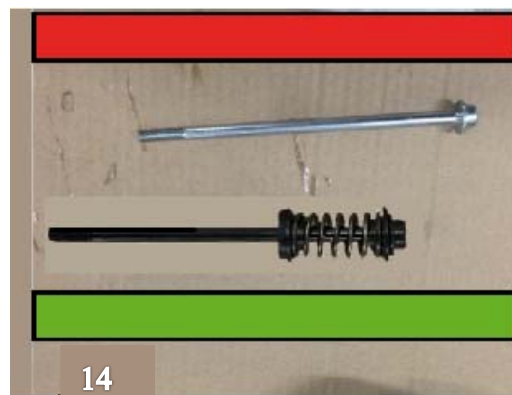

15. Insert the new fixing bolt, rebound rubber, two (2) spring guides and spring into the stanchion tube.

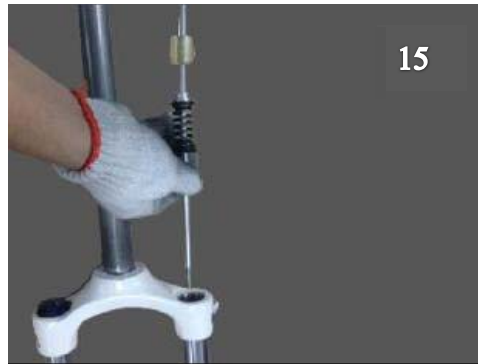

16. Use a 5 mm x 250 mm long Allen/hexagonal wrench on the head of the new fixing bolt to keep the fixing bolt from turning. Insert the bottom stopper.



17. Assemble the threaded washer to the new fixing bolt.



18. Tighten the threaded washer, using the 13 mm box wrench. Tighten to a torque value of no more than 5Nm.



19. Insert the coil spring. **IMPORTANT:** The white spring guide must be at the top of the fork leg.



20. Push and turn the pre-load adjuster knob by hand, in order to engage the thread.



21. Use the plastic pre-load adjuster wrench to tighten the pre-load adjuster knob. Tighten to a torque value of no more than 5Nm.



22. If the forks have two (2) fixing bolts, and the fixing bolt on the other fork leg also failed pre-load the Fixing Bolt Integrity Test Procedure (Section III, above), repeat steps 6 through 21.

23. Assemble the bottom case to the stanchions. **IMPORTANT:** Do not install the bottom case backwards. The brake arch should face forward. Be sure that the marking tape from step 1 is aligned. Remove marking tape.



24. After the bottom case has been fully inserted over the stanchions, the fixing bolt ends should show.



25. Thread on the nut over the fixing bolt. If the forks are equipped with two fixing bolts, retrieve the fixing nut from step 2 and thread it on the other fixing bolt.



26. Tighten both fixing nuts to a torque value of no more than 12Nm, using a 10 mm socket and torque wrench.



27. After this operation is complete, mark both fixing nuts with a permanent colored marker, in order to identify those fixing bolts that have been inspected and replaced.



FORK MODELS INVOLVED IN THE INVESTIGATION

Fork model	Travel	Fixing bolt
SF15-M3010-A-P 24	T50	Right side
SF15-M3010-P 24	T50	Right side
SF15-M3010-P 26	T50	Right side
SF15-M3010-P 26	T63	Right side
SF15-M3010-A-P 26	T50	Right side
SF11-M3010AL-P 26	T63	Right side
SF13-M3020-P 24	T50	Right side
SF13-M3020-DS 24	T50	Right side
SF14-M3020-P 24	T50	Right side
SF14-M3020-A-P 24	T50	Right side
SF13-M3020-A-DS 24	T50	Right side
SF13-M3020-P 26	T75	Right side
SF13-M3020-DS 26	T63	Right side
SF13-M3020-DS 26	T75	Right side
SF13-M3020-A-DS 26	T63	Right side
SF13-M3020-A-DS 26	T75	Right side
SF13-M3020-P 26	T63	Right side
SF13-M3020-P 26	T75	Right side
SF13-M3020-A-P 26	T63	Right side
SF13-M3020-A-P 26	T75	Right side
SF14-M3030-P 26	T63	Right side
SF14-M3030-P 26	T75	Right side
SF14-M3030-DS 26	T75	Right side
SF14-M3030-A-P 26	T75	Right side
SF14-M3030-DS 27.5	T75	Right side
SF14-M3030-DS 27.5	T63	Right side
SF14-M3030-P 27.5	T63	Right side
SF14-M3030-P 27.5	T75	Right side
SF14-M3030-A-P 27.5	T75	Right side
SF14-M3030-P 29	T75	Right side
SF14-M3030-A-P 29	T75	Right side
SF14-M3030-DS 29	T75	Right side
SF14-M3030-A-DS 29	T75	Right side
SF14-M3030-A-DS 29	T63	Right side
SF14-NEX-C51-P 700C	T63	Right side
SF14-NEX-C51-P 700C	T50	Right side
SF14-NEX-DS 700C	T50	Right side
SF14-NEX-DS-700C	T63	Right side
SF14-NEX-P 700C	T50	Right side
SF13-XCT-JR-P 20	T40	Right & Left side
SF13-XCT-P 26	T100	Right & Left side
SF13-XCT-PM-P 26	T100	Right & Left side
SF13-XCT-PM-DS 26	T100	Right & Left side
SF15-XCT-PM DS 27.5	T80	Right & Left side
SF15-XCT-PM-DS 27.5	T100	Right & Left side
SF16-XCT-PM-DS 27.5	T100	Right & Left side
SF13-XCT-PM-DS 29	T100	Right & Left side
SF14-XCT-PM-DS 29	T100	Right & Left side
SF15-XCT-PM-DS 29	T80	Right & Left side
SF16-XCT-PM-DS 29	T80	Right & Left side
SF15-XCT-PM-DS 29	T100	Right & Left side
SF16-XCT-PM-DS 29	T100	Right & Left side

3722761.12